

## HRSDT 600

ceramic

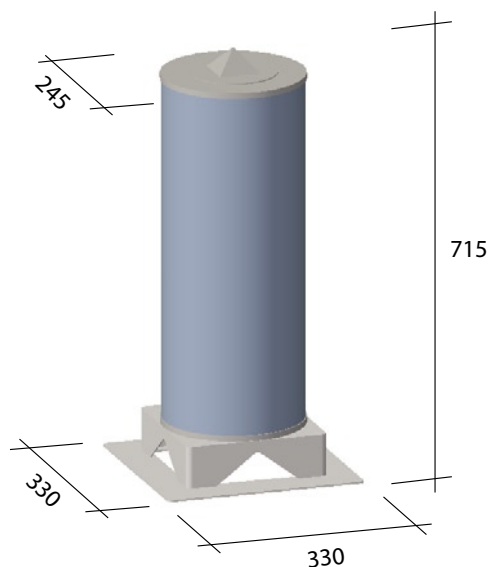

Electric ceramic storage stove, with prevalently radiated heat.  
Different colors and custom hand-decorated.

<b>Supply voltage</b>	230 V ~ 50+60Hz
<b>Power</b>	300W - 600W
<b>Fuse</b>	4 A
<b>Exchange surface</b>	0,634 mq
<b>Weight</b>	≈ 20 Kg.

## HRSDT 600

keramik

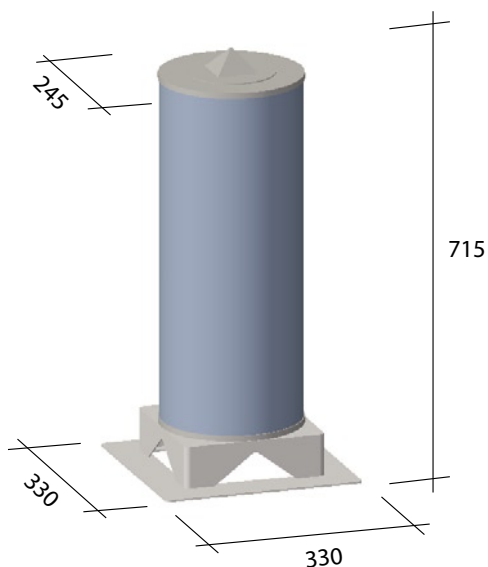

Elektro-Speicherofen aus Keramik, mit Wärmeübertragung in Form von Infrarotstrahlung.  
Keramik und handdekorierte Kacheln in verschiedenen Farben und Farbtönen.

<b>Netzspannung</b>	230 V ~ 50+60Hz
<b>Leistungsverbrauch</b>	300W - 600W
<b>Schmelzsicherung</b>	4 A
<b>Tauscherfläche</b>	0,634 mq
<b>Gewicht</b>	≈ 20 Kg.

## HRSDT 600

ceramica

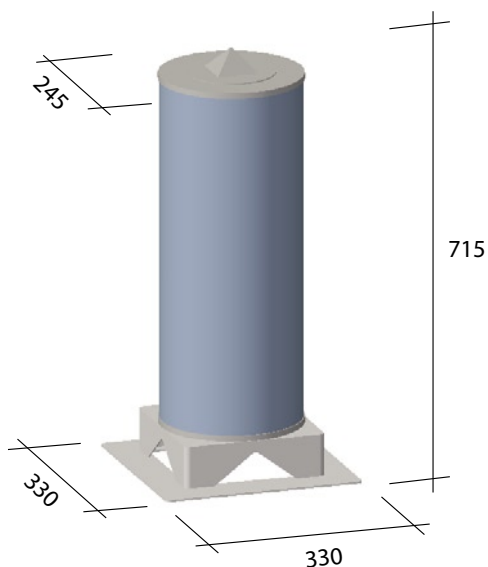

Stufa elettrica ad accumulo in ceramica, a prevalente trasmissione del calore per irraggiamento.  
Differenti colorazioni e decorazioni a mano personalizzate.

<b>Tensione di rete</b>	230 V ~ 50+60Hz
<b>Potenza</b>	300W - 600W
<b>Protezione fusibile</b>	4 A
<b>Superficie scambio</b>	0,634 mq
<b>Peso</b>	≈ 20 Kg.