

HRST 600 SE

ceramic

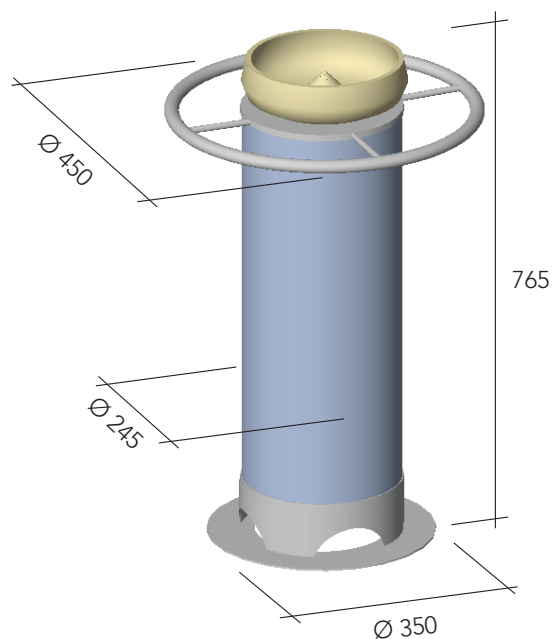

Electric ceramic storage stove, with prevalently radiated heat.
Different colors and custom hand-decorated.

Supply voltage	230 V ~ 50+60Hz
Power	300W - 600W
Fuse	4 A
Exchange surface	0,634 mq
Weight	≈ 21 Kg.

HRST 600 SE

keramik

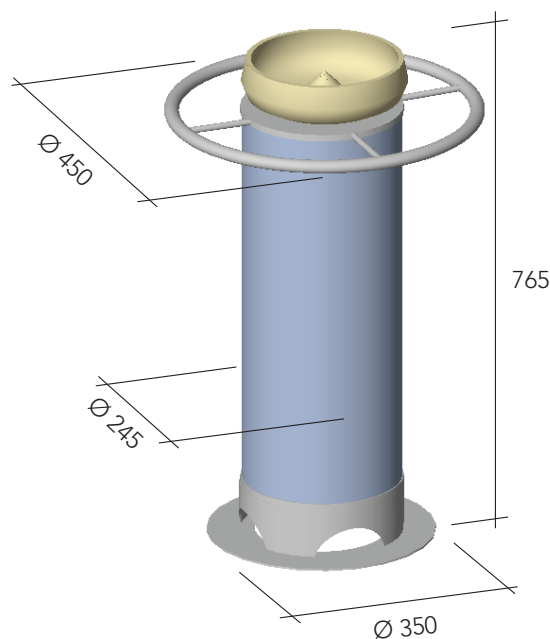

Elektro-Speicherofen aus Keramik, mit Wärmeübertragung in Form von Infrarotstrahlung.
Keramik und handdekorierte Kacheln in verschiedenen Farben und Farbtönen.

Tensione di rete	230 V ~ 50+60Hz
Potenza	300W - 600W
Protezione fusibile	4 A
Superficie scambio	0,634 mq
Peso	≈ 21 Kg.

HRST 600 SE

ceramica

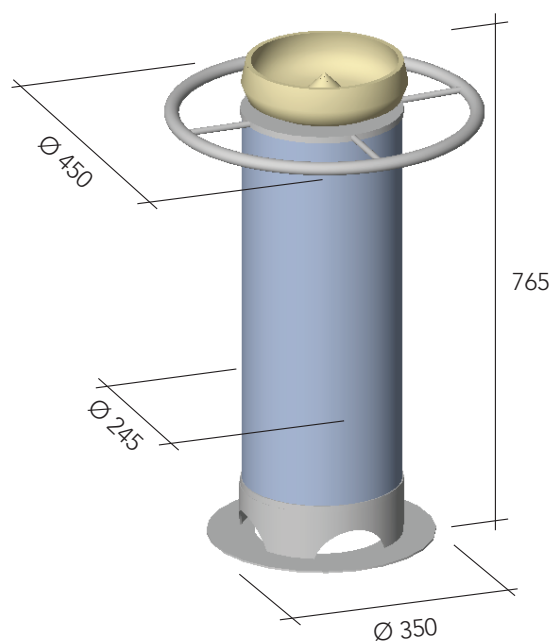

Stufa elettrica ad accumulo in ceramica, a prevalente trasmissione del calore per irraggiamento.
Differenti colorazioni e decorazioni a mano personalizzate.

Tensione di rete	230 V ~ 50+60Hz
Potenza	300W - 600W
Protezione fusibile	4 A
Superficie scambio	0,634 mq
Peso	≈ 21 Kg.